

# APPC 1235T

12.1" TFT XGA 4:3 Flush Panel PC with Intel® Atom™ D2550,  
1.86GHz, Touch Screen, 1GB DDR3, 4x USB, 2x COM and VGA



## Main Features

- 4:3 12.1" XGA Fanless LED Panel Computer
- Intel® Atom™ D2550, Dual Core, Low Consumption CPU
- Flush Panel by 5-wire Touch Screen
- Dual GbE/ 2nd display-VGA/ Line-in/ Line-out/ MIC-in/ PS2 KB/MS
- USB x4/ 2x Mini-PCIe sockets/ 1x CFast/ 2x RS232/422/485
- Optional 3.5G/ Wi-Fi Module/ 2.5" HDD/ 2x COMs/ GPIO /DIO
- DDR3 1GB/ 2.5" HDD Bracket
- IP65 Compliant Front Panel
- Mounting Support: Panel/ Wall/ Stand/ VESA 100mm x 100mm
- Wide Range Power Input 12V~30VDC

## Product Overview

The 12.1" XGA fanless panel PC APPC 1235T incorporating an industrial motherboard is intended for versatile industrial applications. APPC 1235T supports 1024 x 768 (XGA) resolution and 500-nit brightness. The front panel which adopts flush design and complies with IP65 standard makes it the perfect fit in industrial applications.

This APPC series supports WWAN/WLAN expansion and others via dual Gigabit Ethernet connectors, two Mini-PCIe slots and one SIM card holder. With support for wide power input of 12V~30V, this APPC series can gain a strong foothold in industrial field and machine devices. In addition, this APPC series can hook 2nd display via a VGA port for dual independent display.

## Specifications

### Panel

- LED Size: 12.1", 4:3
- Resolution: XGA 1024x768
- Luminance: 500cd/m<sup>2</sup>
- Contrast ratio: 700
- LCD color: 16.2M
- Viewing Angle: 80(U), 80(D), 80(L), 80(R)
- Backlight: LED

### Touch Screen

- 5-wire resistive (flush panel type)
- Light transmission: 80%
- Interface: USB

### System

- CPU: On-board Intel® Atom™ Dual Core processor D2550, 1.86GHz, 1M L2 Cache
- BIOS: AMI BIOS
- System chipset: Intel® NM10 Express chipset
- System memory: 2x 204-pin DDR3 SO-DIMM socket, 1G DDR3 (Default), Support up to 4GB DDR3-800/1066, Non-ECC and Un-buffered

### Storage Device:

- 1x external locked CFast socket
- 1x hard drive bay: optional 1x 2.5" SATA HDD or 1x SATA DOM
- Watchdog timer: Watchdog timeout can be programmable by software from 1 second to 255 seconds and from 1 minute to 255 minutes (Tolerance 15% under room temperature 25°C)
- H/W status monitor: Monitoring system temperature, and voltage
- Expansion: 2x Mini-PCIe sockets (support optional Wi-Fi or 3.5G module)

### Rear I/O

- Ethernet: 2x RJ45
- 2nd display VGA port: 1 x DB15
- Audio port: 1x Line out; 1x Line in; 1x MIC-in
- USB: 4x USB 2.0
- PS2 keyboard/ mouse
- Power switch/ Reset button
- COM #1: RS232/422/485 w/RI or 5V selection
- COM #2: RS232/422/485 w/RI or 12V selection

## Dimension Drawing

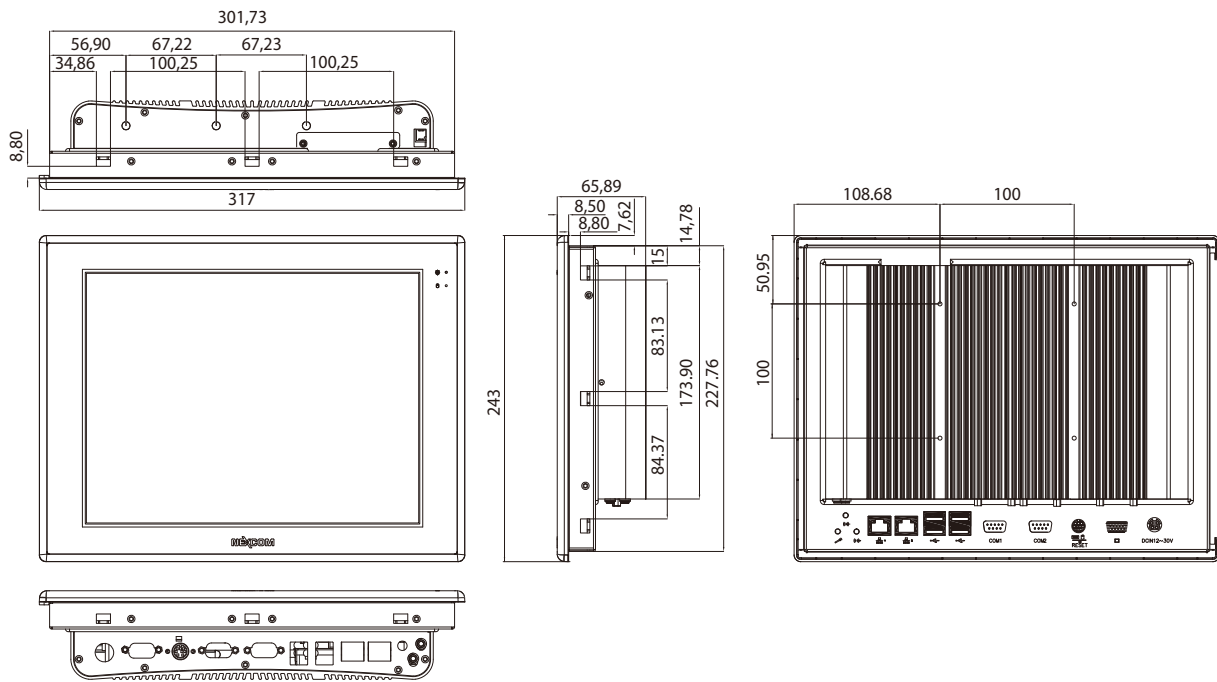

### Audio

- AC97 codec: Realtek ALC886-GR
- Audio interface: Line out/Line in/MIC-in Audio Jack

### Ethernet

- LAN chip: dual Intel® 82574L Gigabit LAN
- Ethernet interface: 10/100/1000 Based-Tx Ethernet compatible

### Mechanical & Environment

- Color: pantone blackRAL 15 00 front bezel w/ Pantone 400C\RAL 090 80 10 metal style membrane
- IP protection: IP65 front
- Mounting: panel/ wall/ stand/ VESA 100mm x 100mm
- Power input: 12V~30VDC
- Power adapter: Optional AC to DC power adaptor (+12V, 60W)
- Vibration:
  - IEC 68 2-64 (w/ HDD)
  - 1Grms @ sine, 5~500Hz, 1hr/axis (HDD Operating)
  - 2Grms @ sine, 5~500Hz, 1hr/axis (CFast Operating)
  - 2.2Grms @ random condition, 5~500Hz, 0.5hr/axis (Non-operating)
- Shock:
  - IEC 68 2-27
  - HDD: 20G@wall mount, half sine, 11ms
- Operating temperature: -5°C to 60°C
- Storage temperature: -20°C to 75°C
- Operating humidity: 10%~90% relative humidity, non-condensing  
Limits to be at 90% RH at max 50°C
- Dimension: 317 x 243 x 65.89mm
- Weight: 3.9 Kg

### Certifications

- CE approval
- FCC Class A

## Ordering Information

### Barebone

- **APPC 1235T (P/N: 10IA1235T00X0)**  
12.1" XGA LED Backlight Touch Panel PC, Intel® Atom™ D2550 1.86 GHz, touch screen, 1GB DDR3, 2x RS232/422/485

### Options

- **12V, 60W AC/ DC power adapter w/o power cord (P/N: 7400060002X00)**